

Data Sheet

DBL-E Motorised Operation Dimout Blind System



Features and Benefits

- 240v motor with range of control options
- Cassette and side channels for enhanced light exclusion
- Various fixing options for cassette and side channels
- LightLock® system retains fabric in side channels
- Safe by design – meets BS EN 13120 child safety requirements
- Available in black or white powder coated finish
- Motor specifications and wiring diagrams available upon request

Configuration

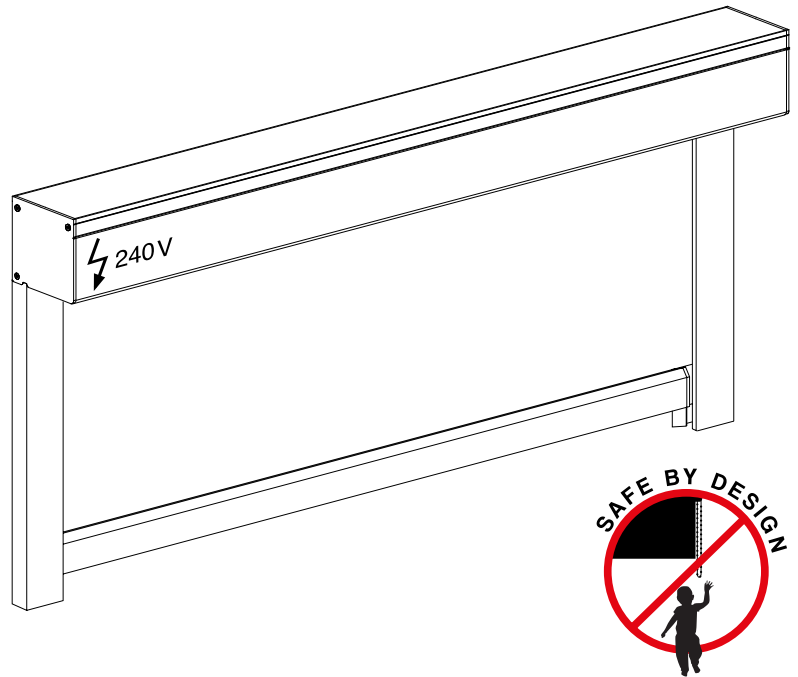

Headbox Options: Square Headbox

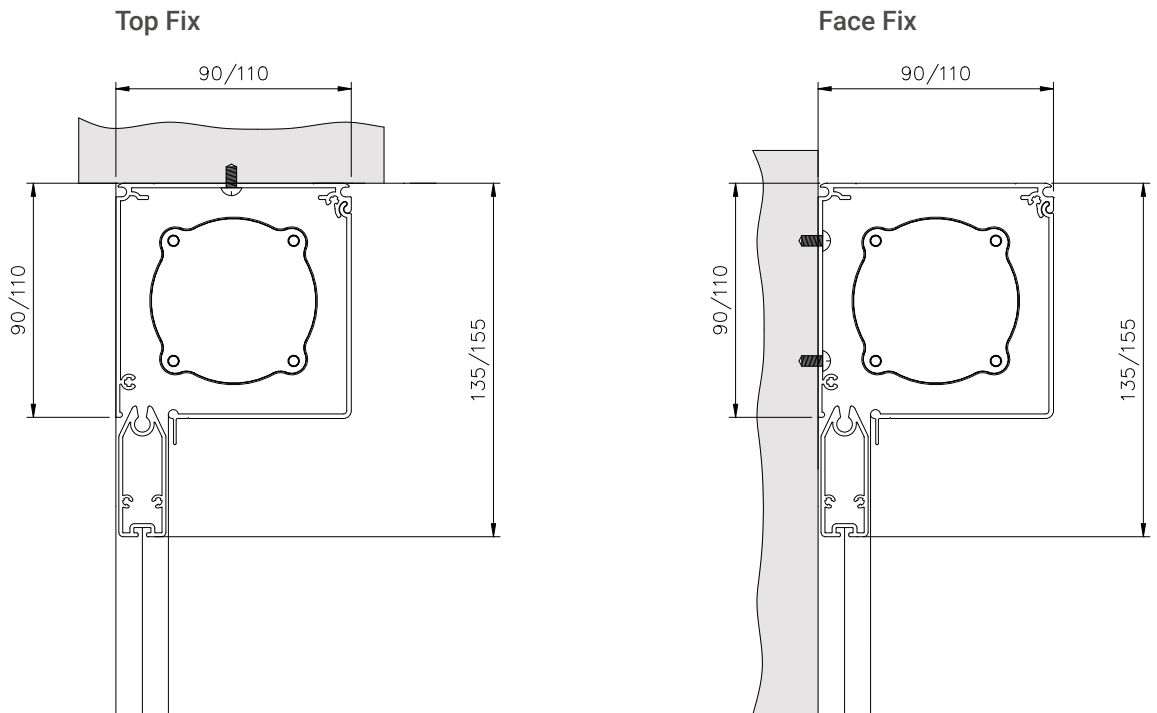

Side Channel Options

Side Channel Face Fix
Inside Reveal

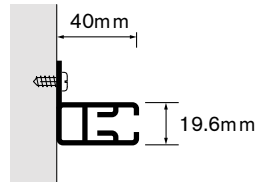

Side Channel Side Fix
Inside Reveal

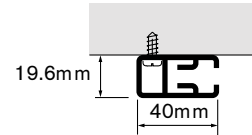

Size Parameters

Minimum width: 650mm
Maximum width: 3500mm
Maximum drop: 3000mm

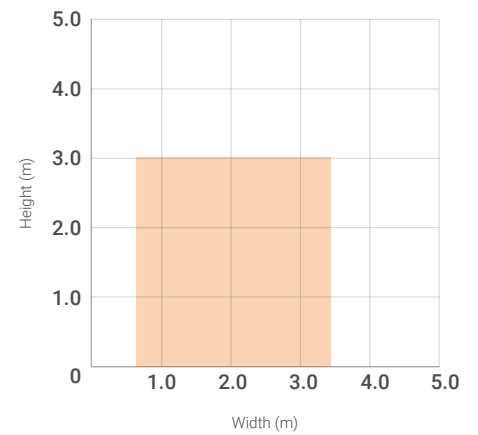

LightLock® Fabric Retention System

Special locking system stops fabric being forced out of the side channels

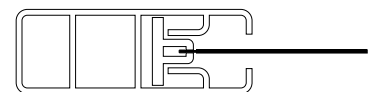
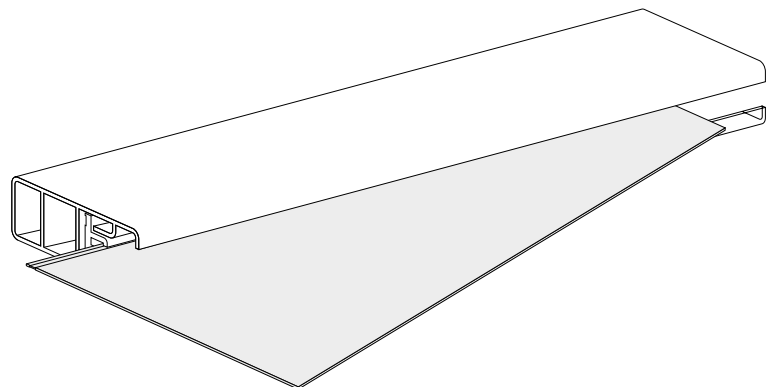



Fabric Choice

DeltaBlock30® and Deltablock40® fabrics are ideally suited to the ShadeTech® DBL Dimout Blind System. Other fabrics available, please [contact Waverley](#) for advice.

Maintenance

ShadeTech® Dimout Blinds are made from high quality materials. Cleaning regime depends upon fabric specified. Most can be wiped clean with a damp cloth.

Quality and Guarantee

ShadeTech® Dimout Blinds are manufactured and installed in accordance with a quality system certified under EN ISO 9001:2000. They are rigorously tested to guarantee trouble free operation, and are designed with health and safety and environmental standards in mind. They carry a five year manufacturer's guarantee.