

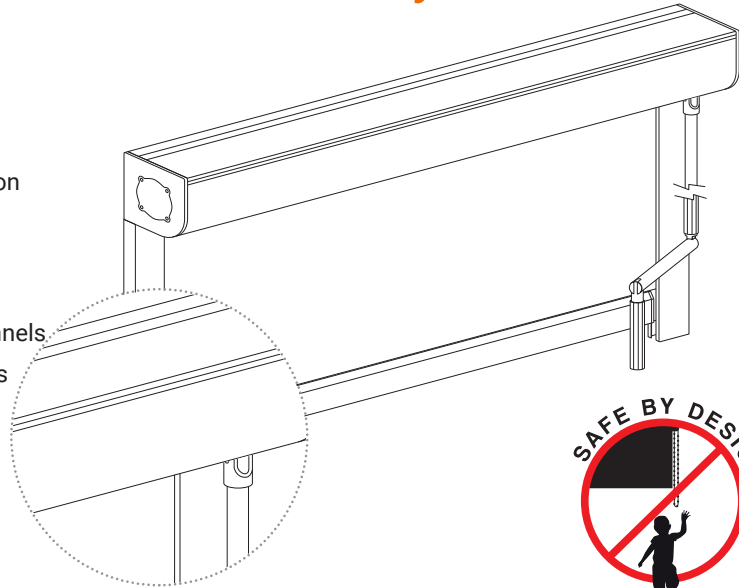

DBL-G Gear Operation Dimout Blind System

Features and benefits

- ▶ Robust fixed or detachable crank handle operation
- ▶ Cassette and side channels for enhanced light exclusion
- ▶ Two sizes of head box – 90mm or 110mm
- ▶ Various fixing options for cassette and side channels
- ▶ LightLock® system retains fabric in side channels
- ▶ Safe by design – meets BS EN 13120 child safety requirements
- ▶ Available in black or white powder coated finish



Fixing options

Top fix

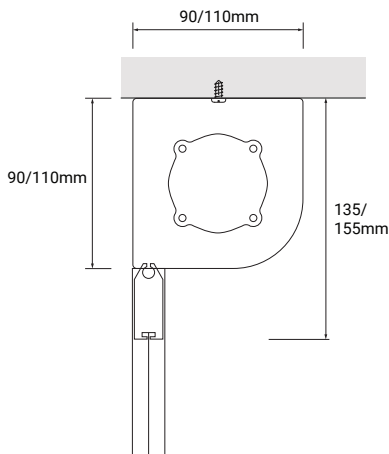

Face fix

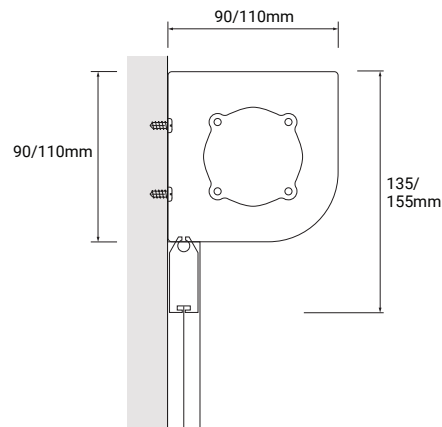

Side channel side fix inside reveal

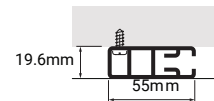

Side channel face fix inside reveal

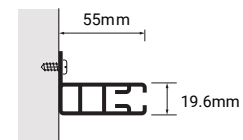

Size parameters

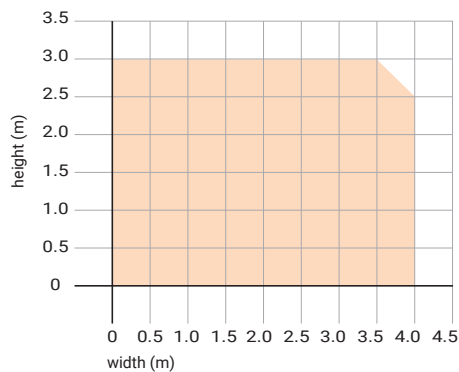

LightLock® fabric retention system

- ▶ Special locking system stops fabric being forced out of the side channels.

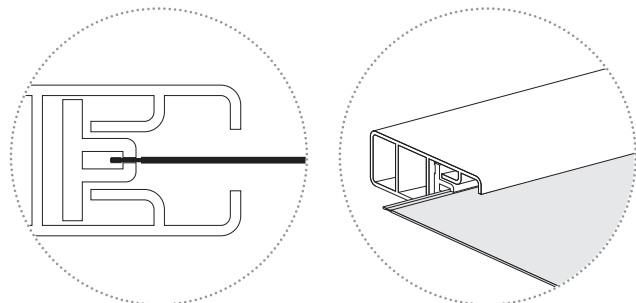



This publication is based on the latest data available at the time of printing. Due to product changes, improvements and other factors, the Company reserves the right to change or withdraw information contained herein without prior notice. The photography shown in the document should not necessarily be taken as recommendations of good practice. The printing process restricts the exact representation of colours. For true colour reference, please request product samples.



Fabric choice

ShadeTech® DeltaBlock® fabric is ideally suited to the ShadeTech® DBL Dimout Blind System. Alternatively, they can be manufactured using the fabric selected by the Specifier or client.

Maintenance

ShadeTech® Dimout Blinds are made from high quality materials. Cleaning regime depends upon fabric specified. Most can be wiped clean with a damp cloth.

Quality and Guarantee

ShadeTech® Dimout Blinds are manufactured and installed in accordance with a quality system certified under EN ISO 9001:2000. They are rigorously tested to guarantee trouble free operation, and are designed with Health and Safety and environmental standards in mind.

They carry a 5 year manufacturer's guarantee.

Basic specification wording

ShadeTech® Dimout Blind System DBL:
[add suffix as above] with 90/110mm extruded aluminium cassette with radiused front edge and 55mm wide extruded aluminium side channels in white. Controls to be [gearbox and crank handle] [motorised with 230V tubular electric motor]. Side channels and fabric to have Wind Class 3 LightLock® fabric retention system. Extruded aluminium bottom bar in white. Fabric to be...

Blinds to be supplied and installed by Waverley Contract and Supply Ltd., Rowan House, Guildford Road Trading Estate, Farnham, Surrey, UK, GU9 9PZ, Tel 01252 737973, E-mail sales@waverley.co.uk

Do not hesitate to contact us on 01252 737973 for assistance with specification wording for the blinds to suit your project. Specifications available on NBS Plus.