

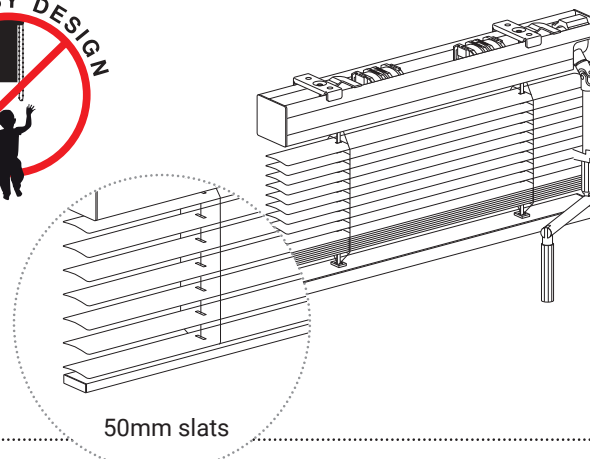

VB-G Gear Operated Venetian Blind System

Features and benefits

- 2:1 gear ratio
- Corrosion resistant roll formed steel headrail
- Headrail, bottom rail and all cords match slat colour
- Heavy duty 6mm wide lift tapes
- Concealed brackets give neat finish
- 50mm wide slats
- Safe by design – meets BS EN 13120 child safety requirements



50mm slats

Fixing brackets

Ceiling fix (top fix) 50mm

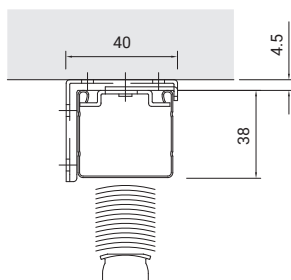

Wall fix (top fix) 50mm

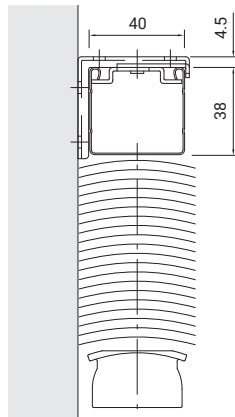

Guide wires

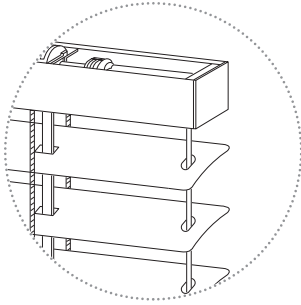

Cill fix bracket

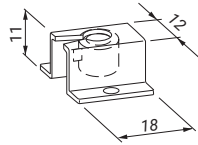

Face fix bracket

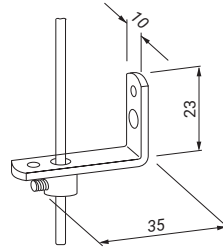

Size parameters

VB-G series (25mm)

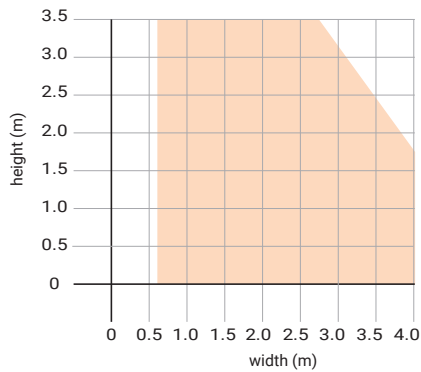

Slat stack heights

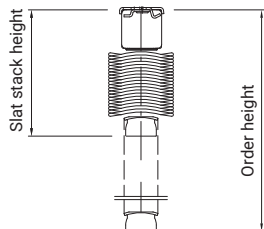

Size of slat	Order height (mm)															
	600	700	800	900	1000	1100	1200	1300	1400	1500	1600	1700	1800	1900	2000	
50mm	95	100	100	105	105	110	110	115	115	120	120	125	125	130	130	

Size of slat	Order height (mm)														
	2100	2200	2300	2400	2500	2600	2700	2800	2900	3000	3100	3200	3300	3400	3500
50mm	135	135	140	140	145	145	150	150	155	155	160	160	165	165	170

Size of slat	Order height (mm)				
	3600	3700	3800	3900	4000
50mm	170	175	175	180	180

CAD details available at www.waverley.co.uk





This publication is based on the latest data available at the time of printing. Due to product changes, improvements and other factors, the Company reserves the right to change or withdraw information contained herein without prior notice. The photography shown in the document should not necessarily be taken as recommendations of good practice. The printing process restricts the exact representation of colours. For true colour reference, please request product samples.



Slat choice

A wide range of colours is available including options of mirror and perforated slats. Please ask for a colour swatch.

Maintenance

ShadeTech® Venetian Blinds are made for high quality materials and require minimal maintenance. Occasional lubrication of cord mechanisms may be required. Slats can be wiped clean with a damp cloth.

Quality and Guarantee

ShadeTech® Venetian Blinds are manufactured and installed in accordance with a quality system certified under ISO9001:2008. They are rigorously tested to guarantee trouble free operation and are designed with Health and Safety in mind. They carry a 5 year guarantee.

Typical specification clause

ShadeTech® Venetian Blind System VB:
[add suffix as above] with [25mm/50mm] aluminium slats. Controls to be by [cord and wand] [mono cord] [geared crank rod] [motorized with 230V tubular motor]. Slat colour... with match cords, headrail and bottom rail.

Blinds to be supplied and installed by Waverley Contract and Supply Ltd., Rowan House, Guildford Road Trading Estate, Farnham, Surrey, UK, GU9 9PZ, Tel 01252 737973, E-mail sales@waverley.co.uk

Do not hesitate to contact us on 01252 737973 for assistance with specification wording for the blinds to suit your project. Specifications available on NBS Plus.