

RBL-C+ Robust Chain Operated Roller Blind System

Features and benefits

- Exceptionally quiet and smooth operation
- White and black end sets and bracket covers
- Choice of white nylon or silver stainless steel control chain
- Heavy duty extruded aluminium rollers
- Brackets for fixing in any situation – standard and extension brackets available
- Includes lift assist spring as standard for ease of operation

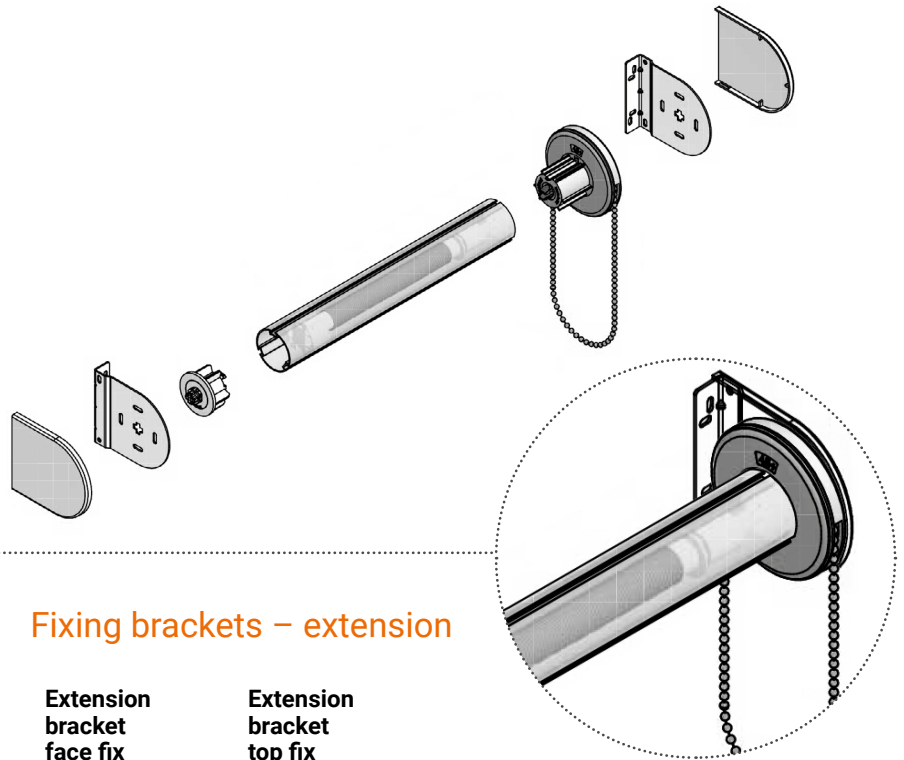

Fixing brackets – standard

Standard metal bracket face fix & cover

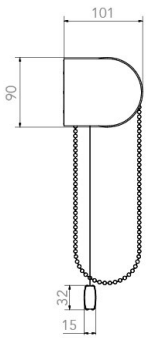

Standard metal bracket top fix & cover

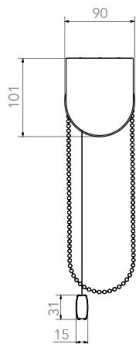

Fixing brackets – extension

Extension bracket face fix

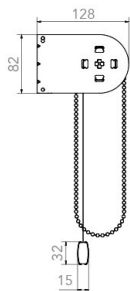

Extension bracket top fix

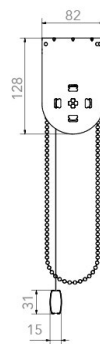

Light gap – single blind

Standard metal bracket top fix front view

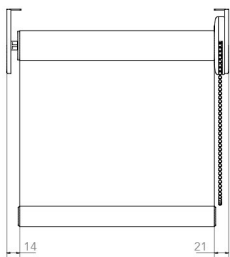

Extension bracket top fix front view

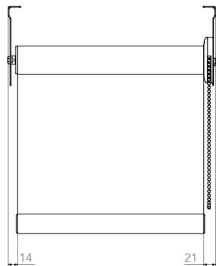

Guide wires

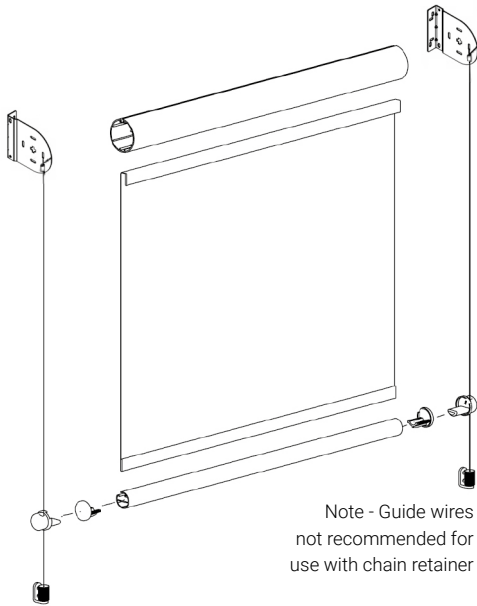

Bottom bar options

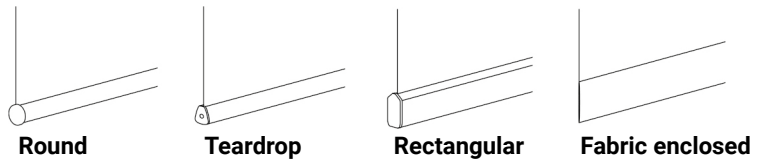

Size parameters

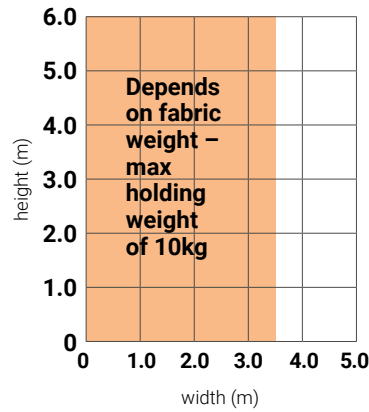

Chain retainer

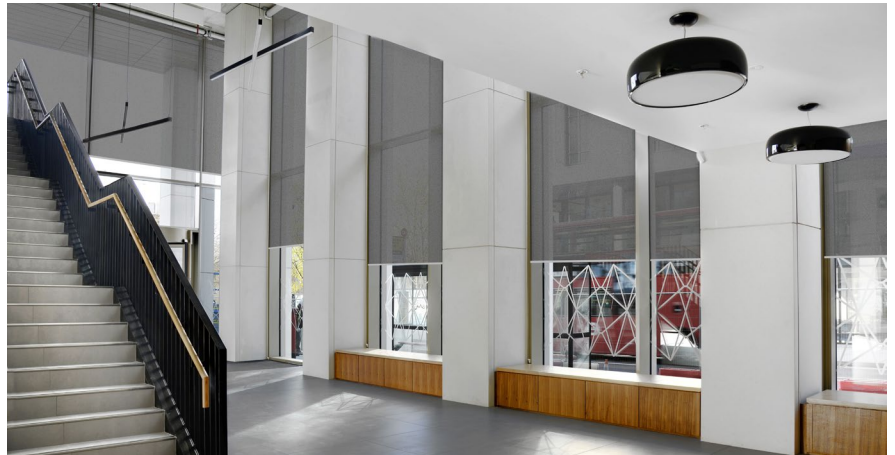
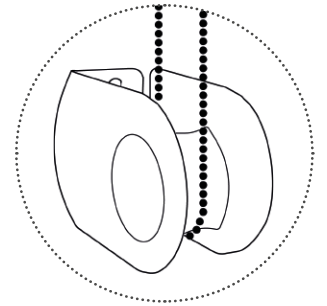

Fabric choice

The entire ShadeTech® fabric range is suitable for use with ShadeTech® RBL-C+ roller blinds.

Alternatively, they can be manufactured using the fabric selected by the specifier or client.

Maintenance

ShadeTech® Roller Blinds are made from high quality materials.

Cleaning regime depends upon fabric specified. Most can be wiped clean with a damp cloth.

Quality and Guarantee

ShadeTech® Roller Blinds are manufactured and installed in accordance with a quality system certified under EN ISO 9001:2000. They are rigorously tested to guarantee trouble free operation, and are designed with Health and Safety and environmental standards in mind.

Contact us on sales@waverley.co.uk or 01252 737973 for assistance with your specification. Specification wording can be downloaded from our website www.waverley.co.uk