



TESS420 DATASHEET

EXTERNAL RAIL-GUIDED TENSION SYSTEM

Designed to minimise the load imposed on your structure.
Any angle, any direction, anywhere.

External systems need strength and weather resistance, but some light glass structures require minimal load. The TESS 420 retains the tension force of the blind within its aluminium frame, distributing system weight evenly through multiple fixing points. Unlimited colour finishes and a wide range of fabrics make it suitable for any project.

- CE marked wind class 3
- Single barrel tension system
- Any angle, any direction
- Minimal load on building
- Guide rails for maximum stability

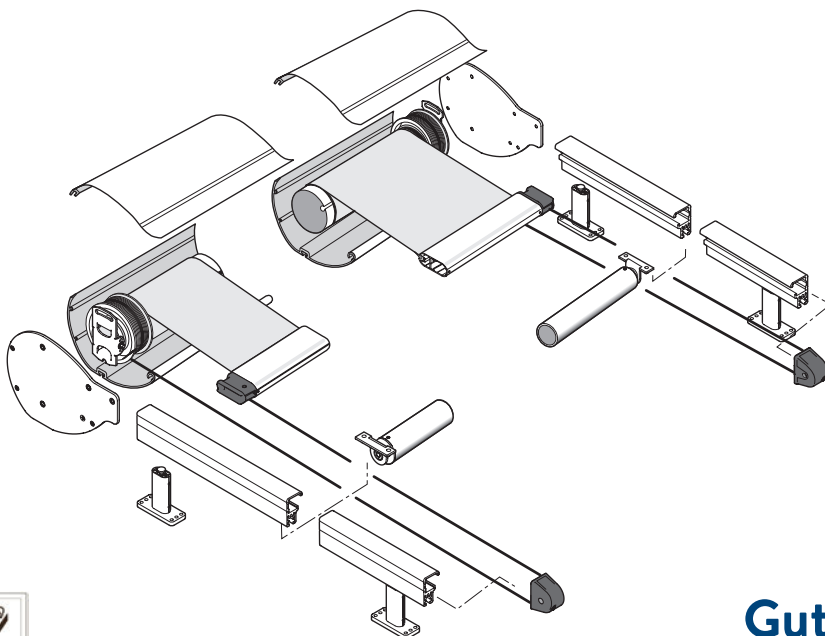

Guthrie Douglas

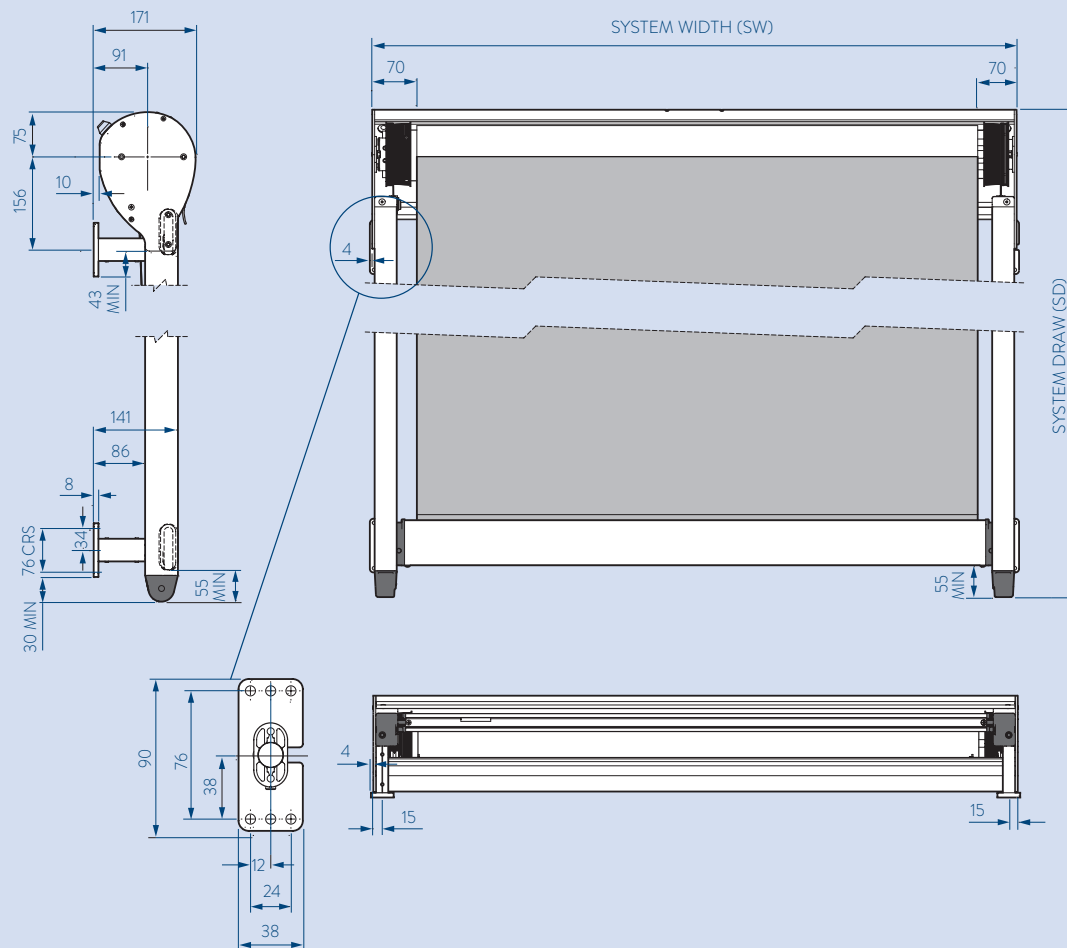

KEYFACTS

Typical use	Light structures, retrofit
Shape	Rectangular
Running direction	Any
Guides	Aluminium profile
Width	870 mm - 4000 mm
Draw	≤6500 mm
Fabric area	≤16 m ²
Brackets	Aluminium
Relieving rollers	Aluminium
Finish	RAL Powder coat
Installation options	Bottom

TECHNICALINFO

Fabric tension	>100 N
Weight exc. fabric	~10.5 kg + 10.2 kg/m + 4kg/m draw
Fixing load	≤7 kg per fixing point
Operating temp.	0 to 55 °C
Motor	15 Nm, 17 rpm
Electrical	230 V, 50 Hz, 140 W, 0.65A
	120 V, 60 Hz, 130 W, 1.1A
Max run time	4 min
Fabric speed	~5 m/min
Controls	Radio, Wired

